

Maintenance and Lubrication

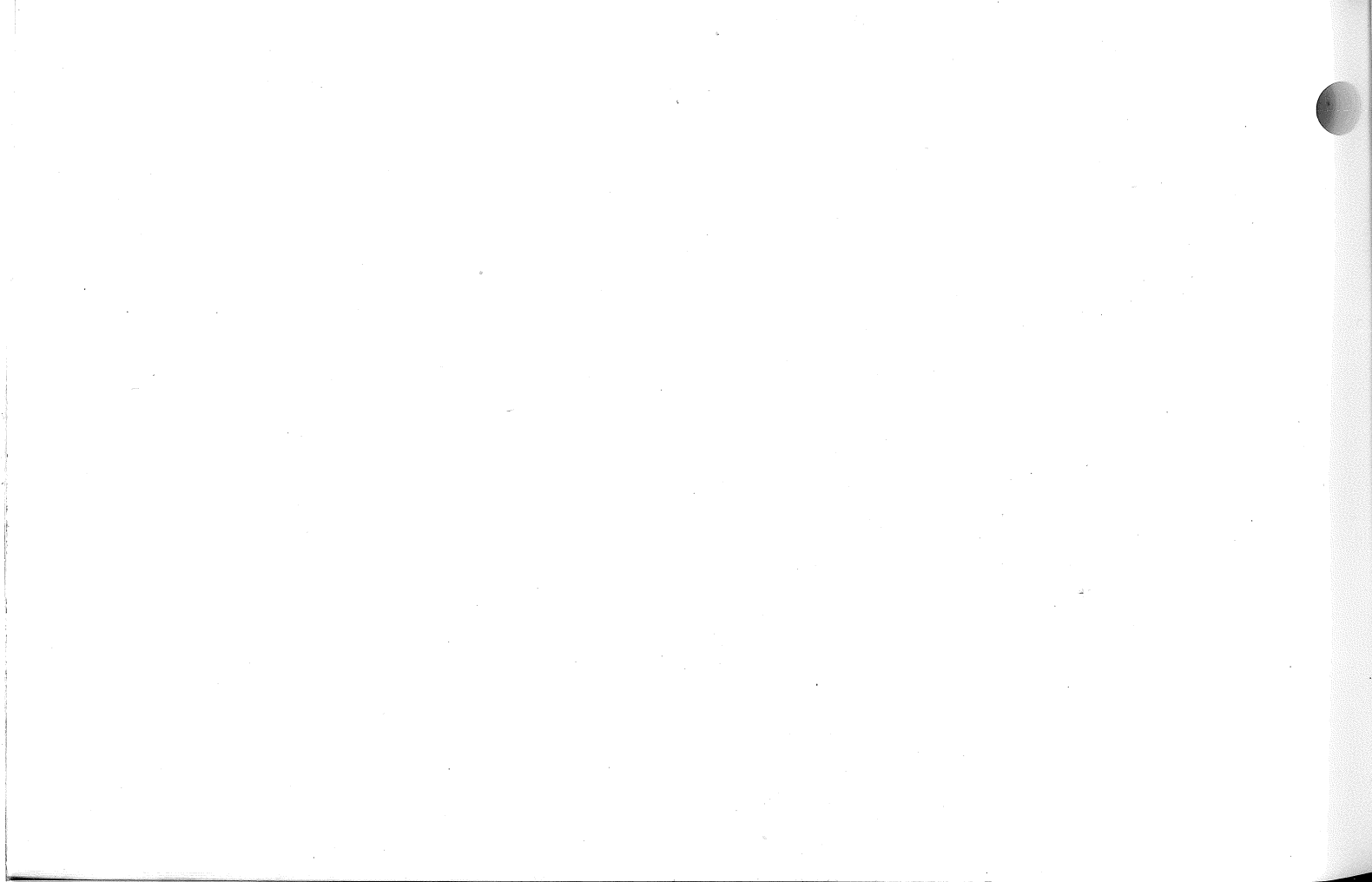

Table of Contents

Service Position	14-5
Winter Air Intake Hood	14-6
Engine Air Filter Elements	14-6
Other Engine Filter Elements	14-9
Hydraulic Oil Filter Condition Indicator	14-9
Hydraulic System Filter Element	14-9
Transmission Filter Element	14-10
Grease Fittings.....	14-10
Circle Lubrication	14-11
Front Wheel Bearings	14-11
Blade Lift Stirrup Nuts	14-12
Tire Inflation	14-12
Tire Pressures Chart	14-13
Hand Brake Adjustment Frequency - All Models	14-14
Hand Brake Cable Adjustment - Models 710 through 740A	14-14
Hand Brake Caliper Adjustment - Models 710 through 740A	14-15
Hand Brake Function Test - Models 710 through 740A.....	14-15
Hand Brake Function Test - Models 750 through 780A.....	14-16

Table of Contents *continued*

Hand Brake - Burnishing Friction Pads - All Models	14-17
Hand Brake Adjustment - Engine Stall Test - All Models.....	14-17
Service Brakes Master Cylinder Fluid	14-18
Engine Cooling System	14-18
Cooling System Capacities	14-20
Battery Problems.....	14-20
Batteries - Jumper Cable Procedure	14-21
Toolbox	14-23
Lubrication Points	14-24
Lubrication Specifications	14-26
Cold Weather Operation - Lubricant Requirements for Transmission and Hydraulic Systems	14-29
Cold Weather Start Up Procedure	14-29

Service Position

Before making any service, maintenance or inspection procedure, the grader must be placed in the **Service Position**.

1. Park the grader on a level surface.
2. Place the transmission in NEUTRAL and apply the hand brake.
3. Lower the moldboard and all attachments to the ground. Do not apply down-pressure.
4. Shut down the engine.
5. If the grader is an articulated model, install both articulation lock pins.
6. Install chocks at the front and rear tandem wheels. Wedge the chocks in place.
7. Relieve residual hydraulic pressure by operating all control levers.
8. Some hydraulic circuits may contain lock valves. Operating the control levers in these circuits will not relieve residual hydraulic pressure. Such pressure must be relieved by loosening a fitting or electrically activating the solenoid valve. Wear face and eye protection. Danger of spraying oil!

9. Fasten a 'DO NOT OPERATE' or similar warning tag on the steering wheel.

10. Remove and retain the ignition key.

11. Turn the battery isolation switch(es) to the OFF position.

12. If the service procedure includes welding, you must disconnect the following items:

- a) The negative battery cable(s).
- b) Positive battery cable(s).
- c) Main power supply harness at the transmission controller.
- d) Transmission wiring harness at the transmission controller.
- e) Alternator wiring harness.

Connect the arc-welder ground cable adjacent to the work area. Install the battery box cover(s). After completing your welding procedure, connect items a) through e) in the reverse order. Ensure to connect the negative battery cable(s) last.

13. Allow the engine and hydraulic system to cool before working in these areas.

14. Be aware of other service personnel in your work area.

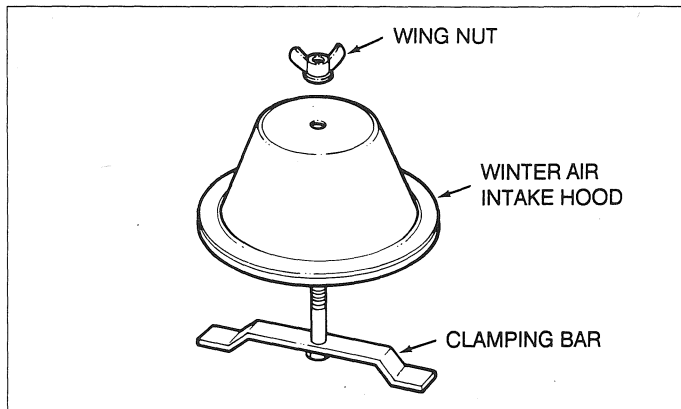

Winter Air Intake Hood

Use the winter air intake hood in place of the air intake stack and rain cap when clearing snow. Installing the winter air intake hood prevents snow clogging the air filter assembly.

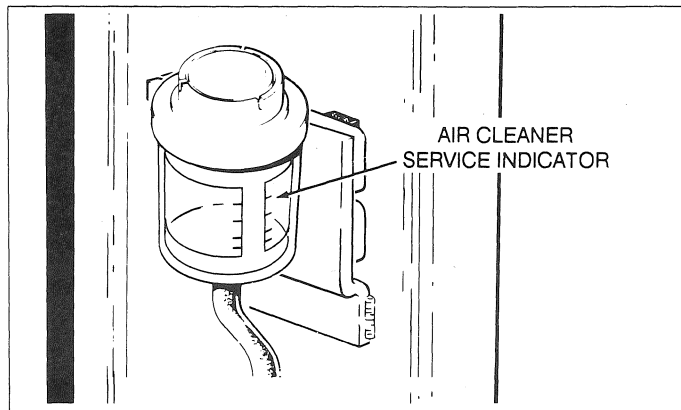

Engine Air Filter Elements

Champion graders are equipped with service indicators which show the actual condition of the filter elements. Service the primary element only when the indicator reaches the red 25 in. (635 mm) line on the transparent body. To reset the indicator after service, press the button at the bottom of the body.

⚠ WARNING

When using pressurized air for cleaning, wear a face shield and protective clothing. Do not direct the air hose nozzle at yourself or others. Severe personal injury could result.

Engine Air Filter Elements continued

- To service the air cleaner, remove all the dirt from around the housing cover.
- Remove the wing nut and cover.
- Remove the primary element from the housing. Take care not to damage either the primary or safety elements.
- Using regulated compressed air, clean the primary element. Always direct the pressurized air from inside the element outward and in the opposite direction of the normal air flow. High air pressure can destroy the element. Hold the air nozzle 1 to 2 in. (25 to 50 mm) away from the filter element.
- Carefully check the element, replace it if it shows any signs of damage. Re-use of a damaged element can cause contamination of the engine.
- Remove any dirt from inside the housing by wiping with a damp cloth.
- Do not attempt to clean the primary element by striking it. This can easily damage the element.

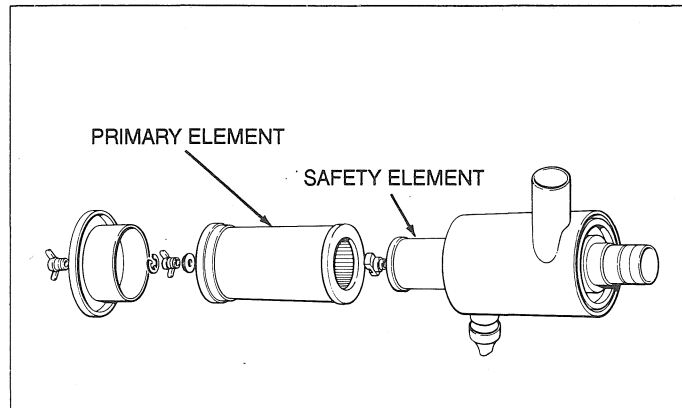

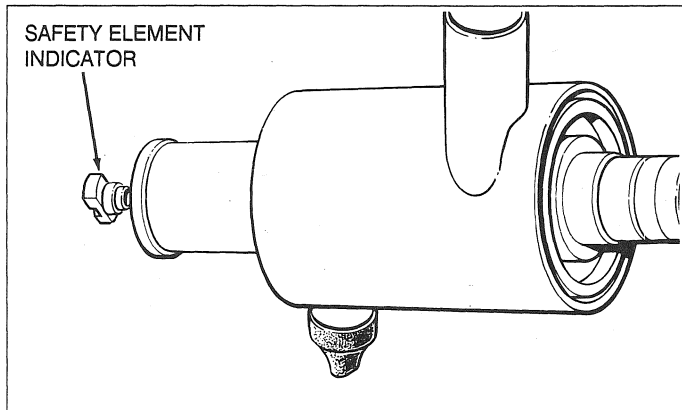

Engine Air Filter Elements continued

- Check the safety element indicator. If the indicator shows a small green dot in the indicator window, the element is good. Do not remove the safety element. If the window is completely red, the element is clogged.
- Clean the air cleaner housing completely and remove the indicator and safety element.
- Install a new safety element.
- Apply suction to the indicator window to reset it.
- Install the indicator and tighten it only enough to seat the safety element firmly inside the air cleaner housing.
- Install the primary element, cover and wing nut. Tighten the wing nut by hand.
- Check the tubes and connections leading from the air cleaner to the engine. Look for loose clamps, cracks, or accumulation of dust which may indicate a leak. Periodically check the restriction indicator hose and the vacuator valve to ensure they are unclogged and in good condition.

All Wheel Drive Hydraulic System Filter

Refer to the section - All Wheel Drive, page 12-9.

Other Engine Filter Elements

Detailed information on the lubricating oil filter element(s), coolant conditioner/filter and fuel filter element(s) can be found in the engine operation and maintenance manual that is included in your manual package.

Hydraulic Oil Filter Condition Indicator

Some machines are equipped with a visual filter condition indicator mounted on the primary hydraulic and/or transmission filter heads. If the indicator shows green, the filter is working correctly. If the indicator shows red, you must change the filter element. Check the indicator with a cold engine running at high rpm.

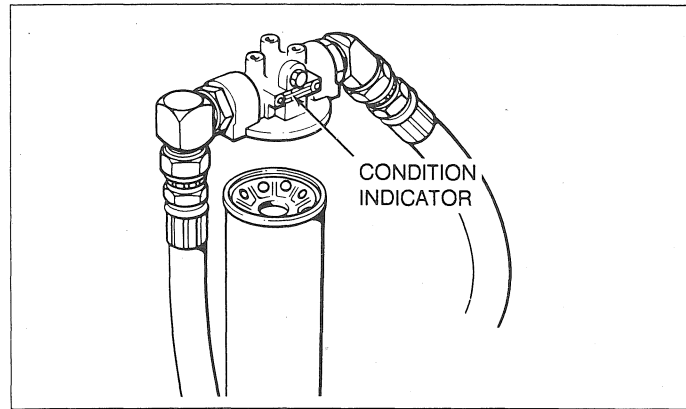

Hydraulic System Filter Element

The primary hydraulic filter is located beneath the fuel tank, inside the left-hand access cover.

- Replace it every 500 hours of operation.
- The filter element is a spin-on type and can be removed with a filter wrench.
- Clean any accumulated dirt from the old filter before removing it.
- To install a new filter element, first apply a coating of clean hydraulic oil to the gasket.
- Install the new element on the filter head and tighten it as far as possible by hand only.
- Do not use a filter wrench to tighten the element.

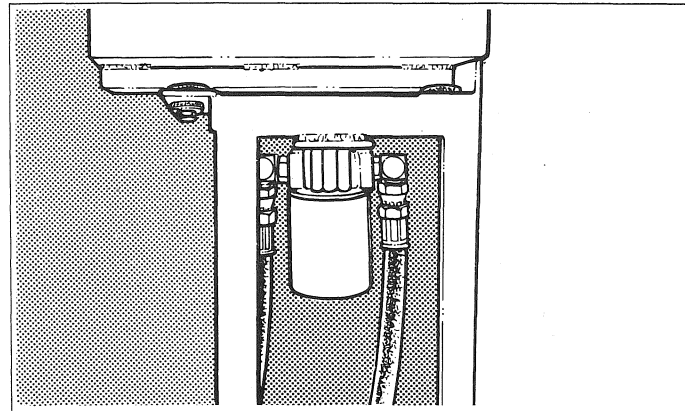

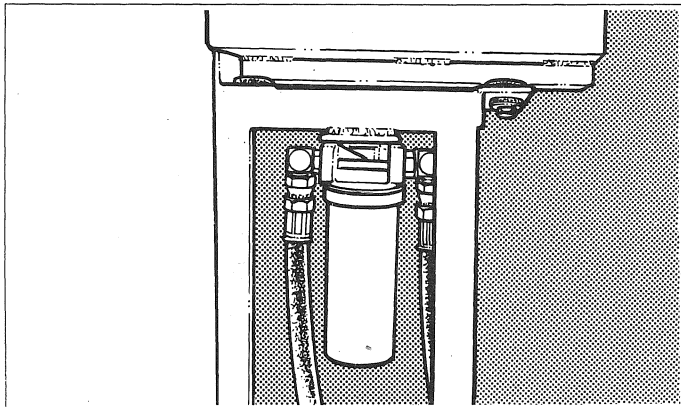

Transmission Filter Element

The transmission filter is located beneath the fuel tank, inside the right-hand access cover.

- Replace it every 500 hours of operation.
- The filter element is a spin-on type and can be removed with a filter wrench.
- Clean any accumulated dirt from the old filter before removing it.
- To install a new filter element, first apply a coating of clean hydraulic oil to the gasket.
- Install the new element on the filter head and tighten it as far as possible by hand only.
- Do not use a filter wrench to tighten the element.

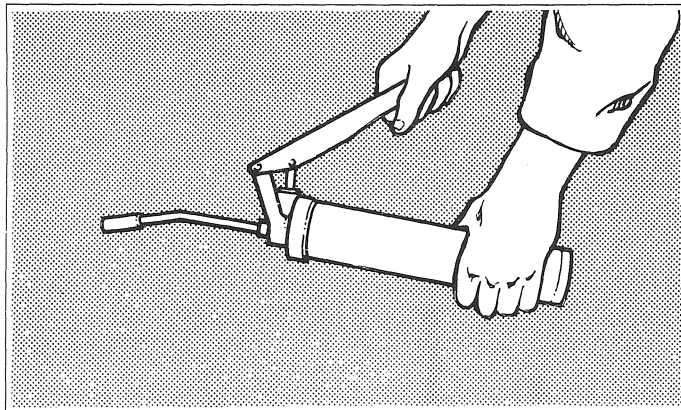

Grease Fittings

- Refer to **Lubrication Points** page 14-24, for the location of all grease fittings.
- Be sure to clean all dirt and accumulated grease from the fittings before attaching the grease gun.
- By following the recommended service intervals, one or two strokes of a hand-lever grease gun will supply the parts with enough grease. Do not over-lubricate. Pressure from excess grease can damage the seals.

Circle Lubrication

- Once a week, use diesel fuel to clean the moldboard slide surfaces, and the top, bottom and inside edges of the circle.
- Lubricate these circle and moldboard areas with a diesel fuel, Champion graphite spray P/N 300CL moistened with diesel fuel or a multi-purpose grease.
- Consult your Champion dealer for other recommendations on circle lubrication for your particular working conditions.

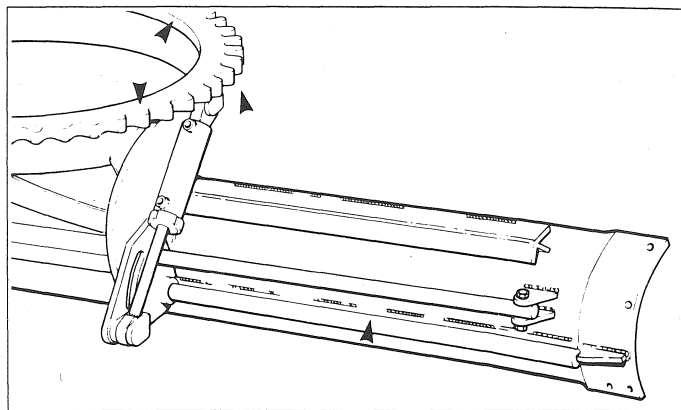

Front Wheel Bearings

- Disassemble, inspect and reset the pre-load of the front wheel bearings every 500 hours. Refer to the **700 Series Shop Manual P/N L-2005**.

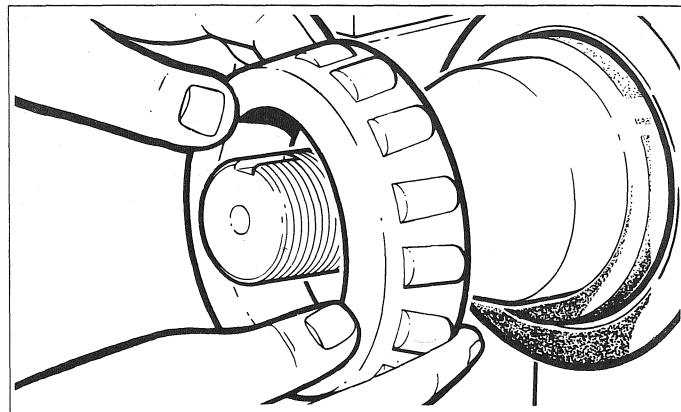

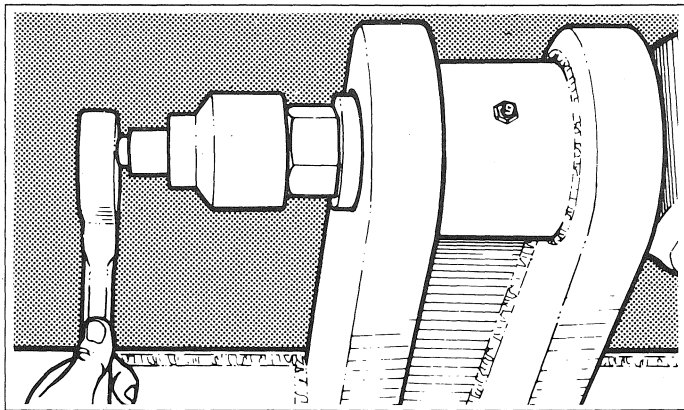

Blade Lift Stirrup Nuts

- Check the tightness of the jam nuts periodically.
- If a jam nut is found loose, then the Blade Lift Stirrup Assembly must be inspected. Refer to the **700 Series Shop Manual P/N L 2005**, for the correct inspection and repair procedures for the Blade Lift Stirrup Assembly.

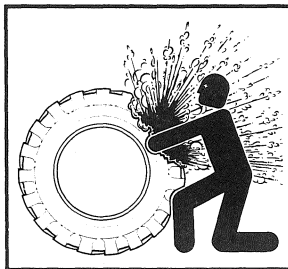

⚠ WARNING

Failure to use a safety cage when inflating tires could result in severe personal injury or death.

Tire Inflation

Tire repair or replacement must be performed by qualified personnel only. Refer to the section - **Safety Precautions - Tire Maintenance Precautions** page 4-19.

⚠ WARNING

Do not weld on the rim. The flame and heat can cause an explosion. The weld can cause premature rim failure. Severe personal injury or death could result.

Tire Inflation continued

- Check the tire pressure with an accurate pressure gauge when the tires are cold. See this page - **Tire Pressures Chart** for recommended maximum pressures. Also refer to the section - **Pre-start Checks - Tire Inflation** page 7-11.
- If wear or other problems related to pressure occur, consult the tire manufacturer.
- To reduce 'gallop', vary the pressures of adjacent tires plus or minus 5 psi (35 kPa).
- Do not stand in front of the tire while you are inflating it.
- Ensure you use a self-attaching air chuck with a remote shutoff and stand behind the tire tread with a safety cage covering the tire while inflating it.
- If 'gallop' persists, make sure your rims are properly installed on the wheel castings and refer to your **700 Series Shop Manual P/N L-2005**.
- Tighten rim clamps in a diagonal pattern. Do not tighten rim clamps in series around the wheel.
- Rim clamp nut torque is 150 lb.ft (203,4 N.m), (20,7 kgf.m).

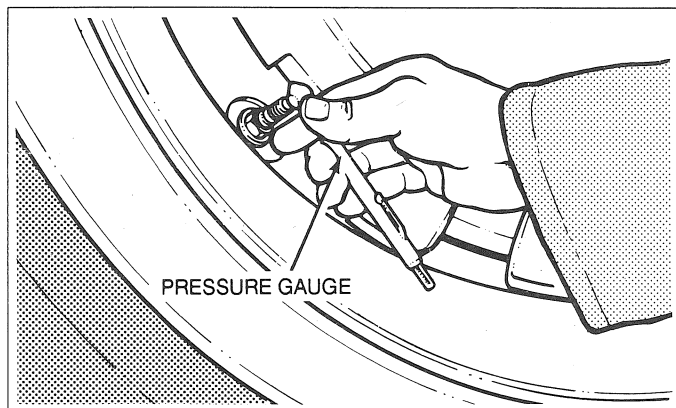

Tire Pressures Chart

Tire Size	Ply	Maximum Pressure	
		kPa	psi
13.00 x 24	12	241	35
14.00 x 24	12	241	35
14.00 x 24	16	241	35
16.00 x 24	12	206	30
16.00 x 24	16	206	30
17.50 x 25	12	206	30
20.50 x 25	12	206	30

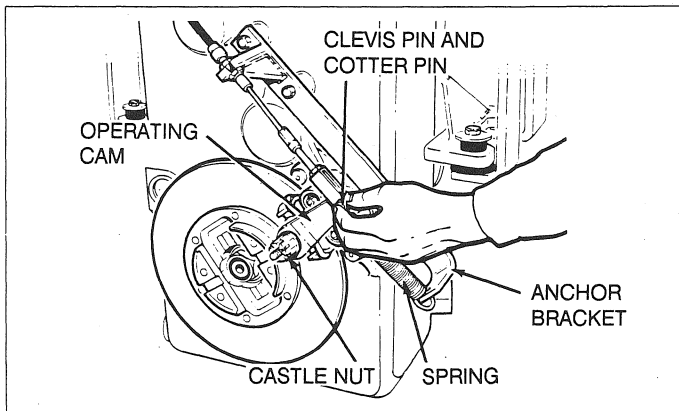
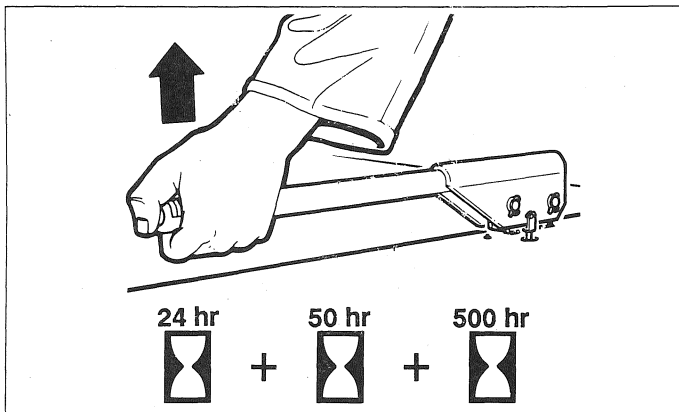

Hand Brake Adjustment Frequency - All Models

- Check the hand brake operation daily. Check that the caliper floating parts move freely and all other parts are secure. Tighten hardware. Refer to the section - **Pre-Start Checks - Hand Brake** page 7-16.
- After 50 hours and at every 500 hours, check for cable stretch and friction pad clearance.
- After using the hand brake for an emergency stop, it must be inspected and adjusted by qualified service personnel.
- Models 750 through 780A have self-adjusting calipers.

Hand Brake Cable Adjustment

- Models 710 through 740A

- Remove and discard the cotter pins securing the cable clevis pin and castle nut.
- Secure the castle nut to finger tightness only.
- Move the operating cam back and forth to determine the lowest point on the cam. Only the slightest amount of play should exist.
- Pull the cable at its free end to remove any slack or lost motion. Move the cam toward the cable to cancel any lost motion between the cam and the push pins.
- Adjust the cable clevis to coincide with the outer hole of the cam. Fully tighten all cable nuts. Install the clevis pin and secure with a new cotter pin.
- Check that the handle locks in all positions. This verifies that the mechanism does not bind.

Hand Brake Caliper Adjustment

- Models 710 through 740A

- Adjust brake cable before adjusting the caliper assembly.
- Loosen the castle nut approximately 1-1/2 to 2-1/2 flats.
- Align one of the castle nut slots with the hole in the caliper assembly threaded rod. The hand brake lever should move five to six ratchet teeth when the brake is properly adjusted. Secure the castle nut with a new cotter pin.

Hand Brake Function Test

- Models 710 through 740A

- After adjusting the hand brake cable or caliper, prepare the grader for a brake function test and engine stall test.
- Make a visual check around the machine. Ensure all personnel are clearly away from the area of the caliper assembly and drive shafts. Signal your intention to start the engine. Start the engine when it is safe to do so.
- Move the grader to an appropriate test area and drive the machine forward in eighth gear at full engine rpm for one minute. Stop the grader and shut down the engine. Remove and retain the ignition key.
- Check the hand brake disc for signs of friction pad drag by carefully determining if the disc is hot.
- If the friction pads are dragging, remove the castle nut cotter pin. Loosen the castle nut by one flat. Replace and secure the cotter pin.

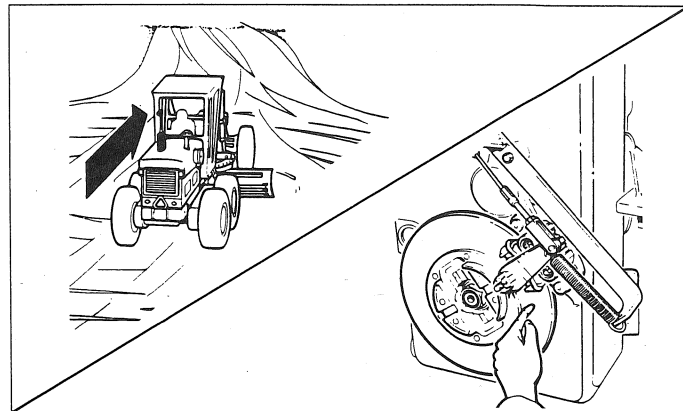
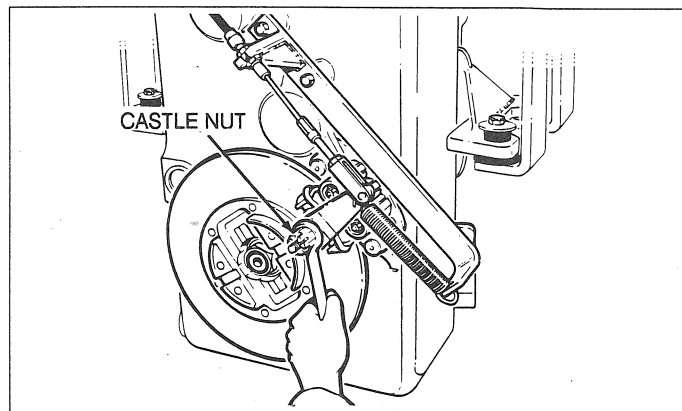

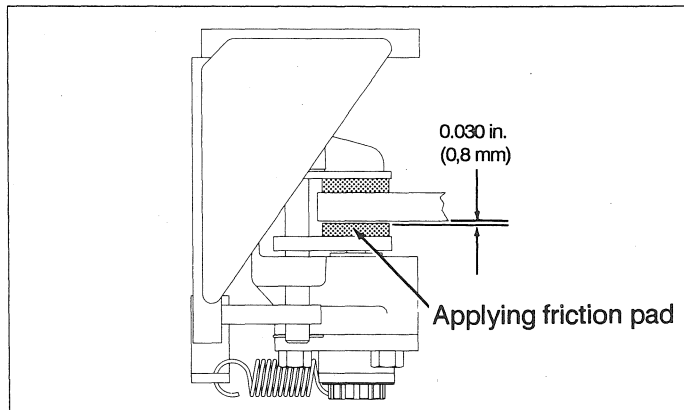
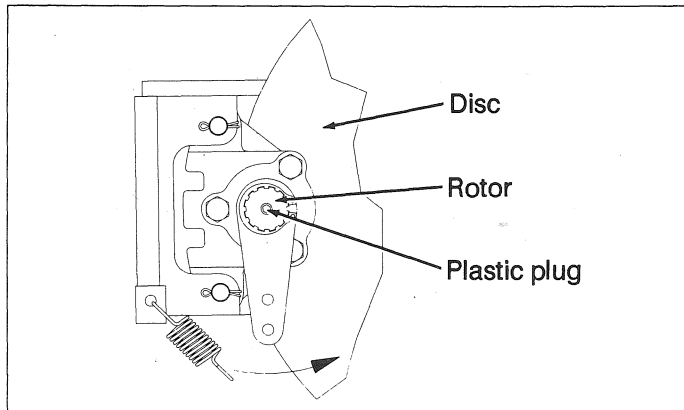

Hand Brake Function Test - Models 750 through 780A

- After any adjustment to the hand brake, prepare the grader for a brake function test and engine stall test.
- Make a visual check around the machine. Ensure all personnel are clearly away from the area of the caliper assembly and drive shafts. Signal your intention to start the engine. Start the engine when it is safe to do so.
- Move the grader to an appropriate test area and drive the machine forward in eighth gear at full engine rpm for one minute. Stop the grader and shut down the engine. Remove and retain the ignition key.
- Check the hand brake disc for signs of friction pad drag by carefully determining if the disc is hot.
- If the friction pads are dragging, remove the plastic plug on the rotor. Insert a 1/4 in. Allen wrench into the shaft and turn counter-clockwise until there is a 0.030 inch (0,8 mm) gap between the applying friction pad and disc. Install the plastic plug.

Hand Brake - Burnishing Friction Pads - All Models

- New friction pads, or pads showing signs of high temperature wear (as in an emergency stop), should be properly burnished as follows.
- Start the engine when it is safe to do so. Drive the machine forward in third gear and lightly apply the hand brake a few seconds at a time to reduce the engine speed.
- Repeat this procedure four or five times until the braking action becomes more aggressive. Stop the grader and shut down the engine.

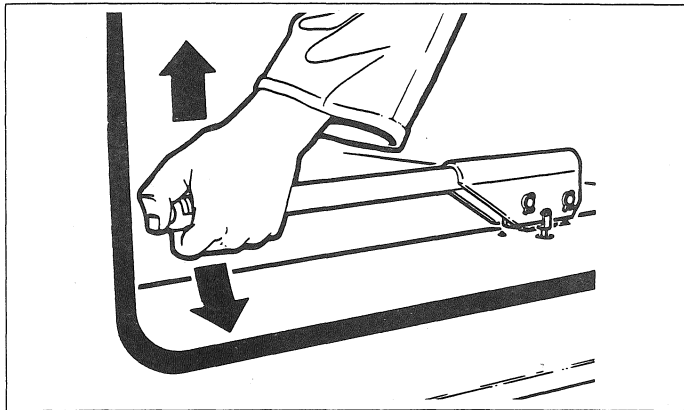

Hand Brake Adjustment - Engine Stall Test - All Models

- Apply the hand brake until the pawl engages the sixth ratchet tooth.
- Start the engine when it is safe to do so.
- Adjust the engine speed to low idle.
- Depress the clutch pedal. Select third speed forward.
- Slowly release the clutch pedal - taking approximately two seconds to do so. The engine must stall. If the engine does not stall, either re-burnish the friction pads or re-adjust the caliper assembly (710 through 740A). Check 0.030 in. (0,8 mm) gap (750 through 780A).
- Repeat this procedure until the engine can be made to stall, but without the hand brake being adjusted too tight.

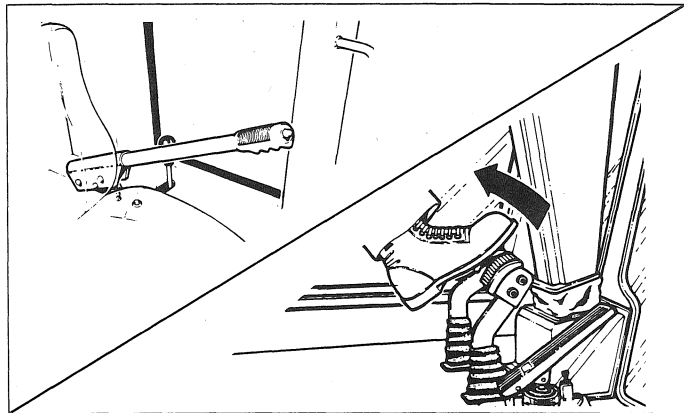

Service Brakes Master Cylinder Fluid

- Graders equipped with drum brakes - use DOT 3 brake fluid in the master cylinder reservoir.
- Graders equipped with oil disc brakes - use petroleum base fluid in the master cylinder reservoir.

Refer to the section - **Maintenance and Lubrication - Lubrication Specifications** pages 14-25 & 14-27, for alternative fluid specifications.

⚠ WARNING

Use only petroleum base fluid in the brake reservoir. Other liquids may cause brake failure. Severe personal injury or death could result. See Operator's Manual for fluid options.

58441

This warning only applies to graders equipped with OIL DISC BRAKES.

Engine Cooling System

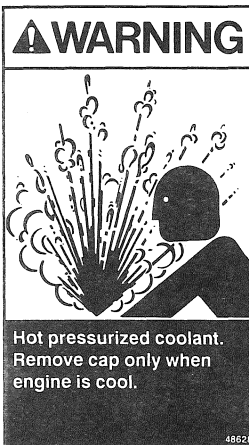

- The engine cooling system is filled at the factory with an antifreeze coolant solution of 60% antifreeze and 40% water. This ensures protection against freezing down to -62°F (-52°C).
- Check the coolant level daily. It should be 2 in. (5 cm) from the top of the filler neck.

Engine Cooling System continued

- Use antifreeze during all seasons to protect against corrosion as well as freezing.
- Use supplemental coolant additives at recommended dosage to control deposits, corrosion and pitting. Over-concentration can result in plugged radiators, heater cores, after coolers and can also cause water pump seal leaks. Refer to Engine Manual.
- Use water that does not contain excess hardness, chloride or sulfate.
- Drain and flush the cooling system as recommended by the Engine Manual.
- Use accurate, reliable equipment to measure coolant antifreeze levels.
- Refer to Engine Manual for testing coolant DCA-4 concentration.
- Follow the Engine Manufacturers' recommendations for precharging the cooling system after draining and flushing.
- Don't add undiluted antifreeze as make up coolant.
- Don't add plain water as make up coolant.
- Don't substitute precharge coolant filters for service filters.
- Don't exceed 68% antifreeze. More than 68% antifreeze reduces freeze protection. The maximum recommended antifreeze level is 60 % which provides freeze protection to -62°F (-52°C). Coolant containing 50% antifreeze provides freeze protection to -34°F (-37°C).
- Don't reuse drained coolant with overconcentrated antifreeze or supplemental coolant additives.
- Don't precharge the cooling system if the coolant is drained and reused.

Cooling System Capacities

Model	U.S. Gallons	Imperial Gallons	Liters
710/710A	10.7	8.9	40,5
720/720A	11.2	9.3	42,5
730/730A	11.2	9.3	42,5
740/740A	10.8	9.0	40,8
750/750A	10.8	9.0	40,8
780/780A	10.8	9.0	40,8

Battery Problems

Shorted Cell	When an electrical load is placed on the battery the cell starts to bubble.
Dead Cell	A 50 point spread in the specific gravity reading between the high and low cell readings indicates that the battery has a bad cell. A voltage reading below 10V also indicates that a battery has a bad cell.
Discharged	When all cells read below a specific gravity reading of 1230, the battery is discharged. The battery should be recharged before an accurate test can be conducted.
Overcharged	A voltage reading above 12.6V and a specific gravity reading above 1265 signifies an overcharged battery.
Open Circuit	When an electrical load test is done on the battery and the needle slowly drops off to zero, check for an open circuit.
Sulfated	An acid filled battery that has been left to sit, without recharging over a long period of time. The end result is that the battery loses capacity and is difficult to reverse the process.

To prevent these problems, you must check the battery acid level, inspect the battery casing for leaks and ensure the specific gravity readings are to specification. Check the specific gravity of the battery when you have received your grader. Recheck it every 3 months. In hot climates recheck it every 2 months.

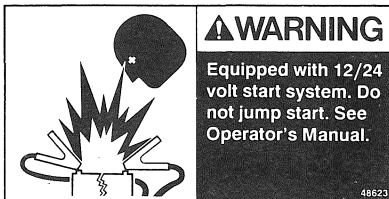

- Allow the battery to warm to 16°C (60°F) before jump starting or charging.

⚠ WARNING

Do not charge or jump start a frozen battery. Gas pressure build-up can cause an explosion. Severe personal injury or death could result.

⚠ WARNING

Handle batteries carefully. Battery acid is extremely corrosive and poisonous. Contact with the eyes, skin, or clothing can result in severe burns or other serious personal injury.

- If contact with battery acid occurs, seek medical attention immediately.
- Wear a face shield when working with batteries.

Batteries - Jumper Cable Procedure

- Before jump starting the grader, determine why the engine will not crank.
- Do not jump start a 12/24 volt start system. Improper connections may cause the batteries to explode resulting in severe personal injury or death. Damage to the booster vehicle's electrical system may also result. Remove the batteries and recharge them separately.
- Batteries produce explosive gases. Keep sparks, flames, smoking materials, or other ignition sources away from batteries. Use a flashlight to check the electrolyte level.

⚠ WARNING

Explosive gases. No smoking. Keep sparks and flames away from batteries.

48626

- Do not let metal objects contact the battery terminals.
- Do not lean over batteries during jump starting procedures.

Batteries - Jumper Cable Procedure continued

Jumper cables can be used to start a 12 volt start system as follows.

- The booster battery and the discharged battery must be of the same voltage. If they are not, electrical arcing could occur and cause an explosion.
- Ensure the moldboard and all the attachments are lowered to the ground.
- Position the vehicle with the booster battery next to the grader's discharged battery without touching the grader. Ensure the batteries are close enough to easily connect the jumper cables.
- Apply the hand brake or emergency brake of both vehicles and move the transmission mode lever of the grader to NEUTRAL. If the other vehicle has an automatic transmission move the lever to PARK, or if the vehicle has a manual transmission move the shift lever to NEUTRAL. Shut down engine. Switch off all unnecessary electrical systems such as lights, heaters, air conditioners in the grader and the vehicle.

- Some batteries have removable vent caps. Remove and clean them. Ensure the vent holes are free of contamination and the caps are installed tightly. Place a wet cloth over the vent caps of each battery. Ensure the cloth is away from any fan blades, belts or any other moving parts.

- Connect the jumper cables from the booster vehicle to the grader in the following order:

- a) Connect positive (+) cable to positive post of discharged battery. Positive post is wired to the starter. Connect other end to positive (+) post of booster battery.

- b) Connect negative (-) cable to negative post of booster battery and other end to body ground or frame. Do not connect to battery.

A wrong connection will cause arcing. Ensure the jumper cables do not contact any moving parts, or other metals.

- Warn all personnel who may be around the vehicle or the grader prior to starting the engines. Do not start the engines until all personnel are clearly away from vehicles.

- Turn the grader's isolation switch(es) to the ON position.

Batteries - Jumper Cable Procedure continued

- Start the engine of the booster vehicle. Allow the engine to run for a few minutes.

- Start the engine of the grader from the operator's seat. Fasten the seat belt. If the engine does not start within thirty seconds, release the ignition key and wait two minutes before trying again. This allows the starter motor to cool. If the engine does not start on the second or third attempt, stop this procedure. Report the problem and have it repaired.

- Do not dismount from the grader with the engine running. Have a qualified service technician disconnect the jumper cables in the reverse order of connection.

- Discard the wet cloth covering the vent caps. Handle the cloth carefully. It may have been contaminated with acid.

- Allow the grader's engine to run for a few minutes and ensure all controls and instruments are working properly before driving or operating the grader.

Toolbox

The toolbox is located in the top of the frame at the front of the machine. The toolbox for graders equipped with All Wheel Drive is mounted on one of the tandem cases.

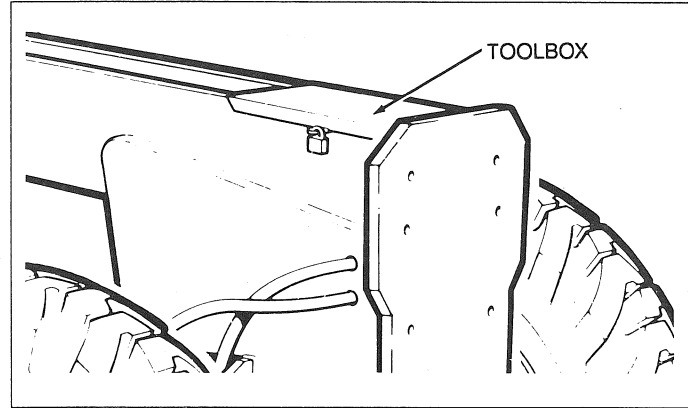

Lubrication Points

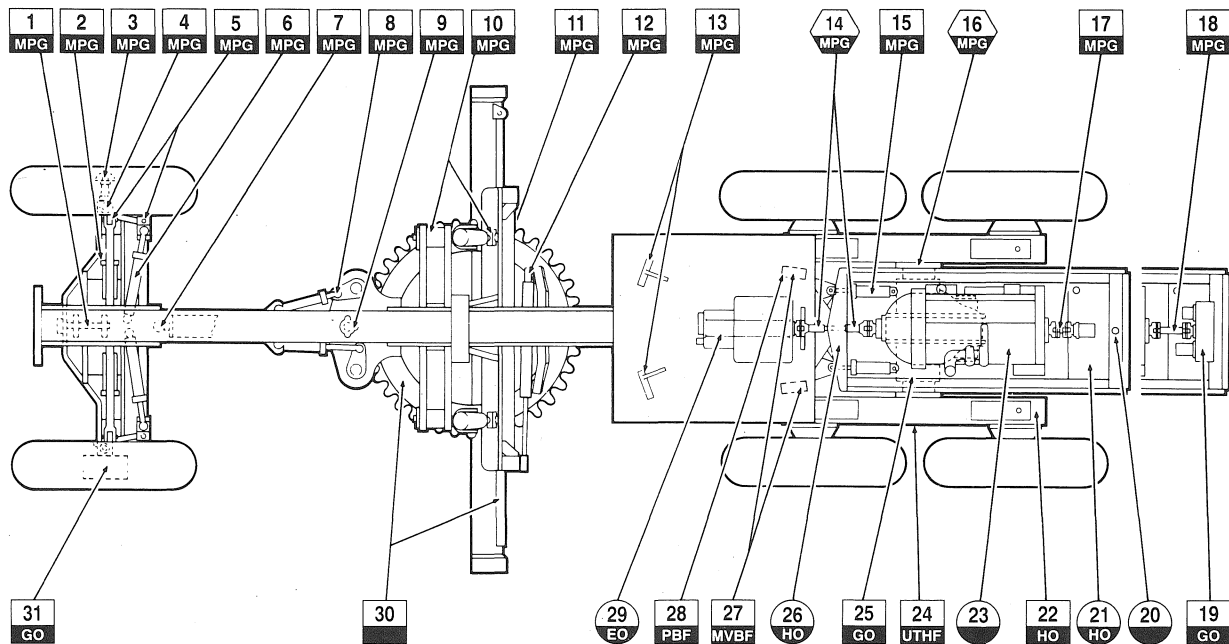

MPG - Multi Purpose Grease
 GO - Gear Oil
 HO - Hydraulic Oil
 PBF - Petroleum Base Fluid

MVBF - Motor Vehicle Brake Fluid
 UTHF - Universal Tractor Hydraulic Fluid
 EO - Engine Oil

 Check Daily

 Check Weekly

 Check Monthly

Champion recommends increasing the greasing frequency in extremely dusty or wet conditions, or if dry joints are apparent.

Key to Lubrication Points - (See next page for Lubrication specifications)

GREASE POINTS - MPG

1. **Pivot Pin** - Two fittings, weekly
2. **Leaning Wheel Cylinder** - Two fittings each side, weekly
3. **Wheel Bearings** - One fitting each side with EP2 grade only, weekly
4. **Knuckle Pivot Pin and King Pin** - Four fittings each side, weekly
5. **Drag Link/Pivot Block/Tie Bar - Standard** - Five fittings, weekly
Heavy Duty - Nine fittings, weekly
6. **Steering Cylinder** - Two fittings each side, weekly
7. **Drawbar Ball Stud** - One fitting, weekly
8. **Circle Turn Cylinder and Crank** - Three fittings each side, weekly
9. **Circle Turn Valve** - One fitting, weekly
10. **Blade Lift System - Fixed Point** - Two fittings each side, weekly
Moveable Point - Nine fittings, weekly
11. **Blade Tilt Cylinder/Tilt Quadrant or Manual Link - Standard** - Two fittings each side, weekly
Heavy Duty - Three fittings each side, weekly
12. **Circle Shift Cylinder** - One fitting each end, weekly

13. **Brake and Clutch Pedal Shafts**
One fitting each, weekly
14. **Upper and Lower Drive Shafts**
Three fittings each shaft, monthly
15. **Articulation Cylinder** - Two fittings each side, weekly
16. **Tandem Sleeve Thrust Plate** - One fitting each side, monthly
17. **Hydraulic Pump Drive Shaft** - Two fittings, weekly
18. **A.W.D. Pump Drive Shaft**
Three fittings, weekly

FLUID LEVELS & LUBRICANTS

19. **A.W.D. Pump Drive Gearbox** GO - check level weekly
20. **Coolant** - See appropriate Engine Operation and Maintenance Manual - check level daily
21. **Hydraulic Oil Reservoir** - HO - check level daily
22. **Tandems** - HO - All models with drum brakes - check level weekly
23. **Engine** - See appropriate Engine Operation and Maintenance Manual - check level daily
24. **Tandems** - UTHF - All models with oil disc brakes (wet brakes) - check level weekly

25. **Final Drives** - GO - check level weekly
26. **A.W.D. Hydraulic Reservoir** - HO check level daily

27. **Drum Brake and Clutch Reservoirs**
MVBF - check level weekly
28. **Oil Disc Brake Reservoir**
PBF - check level weekly

▲WARNING

INCORRECT FLUID WILL CAUSE BRAKE FAILURE. SEVERE PERSONAL INJURY OR DEATH COULD RESULT.

29. **Transmission** - EO - check level daily - warm oil at idle and transmission in neutral
30. **Circle Top; Clamp and Guide Bearing Surfaces; Moldboard Upper and Lower Slide Rails**
Every week or more often as required, wash with diesel fuel - lubricate with:
 - 1) Diesel fuel, or
 - 2) A light coating of Champion graphite spray, P/N 300CL moistened with diesel fuel, or
 - 3) A light coating of MPG
 Keep these bearing surfaces clean.
31. **A.W.D. Planetary Hub** - GO - check level weekly

Lubrication Specifications

Application/ Fluid Code	Capacity	Lubricant Change Interval (see note)	Filter Change Interval	Fluid Type	Air Temperature Range During Fill Period																																																																																																																																																																																																																																																																																																								
					*C -40	-30	-20	-10	0	10	20	30	40	50	*F -40	-22	-4	14	32	50	68	86	104	122																																																																																																																																																																																																																																																																																					
Hydraulic system - HO	42 US gal 159 L	1000 hr	First 100 hr then 500 hr	Hydraulic Oil*									○	SAE 10W, ISO Grade 32																											Dexron®II ATF													All Wheel Drive hydraulic system - HO	10 US gal 38 L	2000 hr	First 100 hr then 1000 hr	Hydraulic Oil*									○	SAE 10W, ISO Grade 32																											Dexron®II ATF														Tandems - drum brakes - HO	8.5 US gal 32 L (each side)	2000 hr	-	Hydraulic Oil									○	SAE 10W, ISO Grade 32																											Dexron®II ATF														Tandems - oil disc brakes - UTHF	26.5 US gal 100 L (each side)	1500 hr	-	Universal Tractor Hydraulic Fluid for Wet Disc Brakes									○	SAE 10W, ISO Grade 32													Front wheel bearings	-	500 hr	Multi-Purpose Grease Extreme Pressure Lithium Soap Base																									All grease fittings - MPG	Until grease seeps from joint	-												○	NLGI EP2 FRONT WHEEL BEARINGS																										NLGI EP0 or EP1																													○	NLGI EP2											
														Dexron®II ATF													All Wheel Drive hydraulic system - HO	10 US gal 38 L	2000 hr	First 100 hr then 1000 hr	Hydraulic Oil*									○	SAE 10W, ISO Grade 32																											Dexron®II ATF														Tandems - drum brakes - HO	8.5 US gal 32 L (each side)	2000 hr	-	Hydraulic Oil									○	SAE 10W, ISO Grade 32																											Dexron®II ATF														Tandems - oil disc brakes - UTHF	26.5 US gal 100 L (each side)	1500 hr	-	Universal Tractor Hydraulic Fluid for Wet Disc Brakes									○	SAE 10W, ISO Grade 32													Front wheel bearings	-	500 hr	Multi-Purpose Grease Extreme Pressure Lithium Soap Base																									All grease fittings - MPG	Until grease seeps from joint			-												○	NLGI EP2 FRONT WHEEL BEARINGS																										NLGI EP0 or EP1																													○	NLGI EP2																																				
All Wheel Drive hydraulic system - HO	10 US gal 38 L	2000 hr	First 100 hr then 1000 hr	Hydraulic Oil*									○	SAE 10W, ISO Grade 32																											Dexron®II ATF														Tandems - drum brakes - HO	8.5 US gal 32 L (each side)	2000 hr	-	Hydraulic Oil									○	SAE 10W, ISO Grade 32																											Dexron®II ATF														Tandems - oil disc brakes - UTHF	26.5 US gal 100 L (each side)	1500 hr	-	Universal Tractor Hydraulic Fluid for Wet Disc Brakes									○	SAE 10W, ISO Grade 32													Front wheel bearings	-	500 hr	Multi-Purpose Grease Extreme Pressure Lithium Soap Base																									All grease fittings - MPG	Until grease seeps from joint			-												○	NLGI EP2 FRONT WHEEL BEARINGS																										NLGI EP0 or EP1																													○	NLGI EP2																																																															
														Dexron®II ATF														Tandems - drum brakes - HO	8.5 US gal 32 L (each side)	2000 hr	-	Hydraulic Oil									○	SAE 10W, ISO Grade 32																											Dexron®II ATF														Tandems - oil disc brakes - UTHF	26.5 US gal 100 L (each side)	1500 hr	-	Universal Tractor Hydraulic Fluid for Wet Disc Brakes									○	SAE 10W, ISO Grade 32													Front wheel bearings	-	500 hr	Multi-Purpose Grease Extreme Pressure Lithium Soap Base																									All grease fittings - MPG	Until grease seeps from joint			-												○	NLGI EP2 FRONT WHEEL BEARINGS																										NLGI EP0 or EP1																													○	NLGI EP2																																																																																										
Tandems - drum brakes - HO	8.5 US gal 32 L (each side)	2000 hr	-	Hydraulic Oil									○	SAE 10W, ISO Grade 32																											Dexron®II ATF														Tandems - oil disc brakes - UTHF	26.5 US gal 100 L (each side)	1500 hr	-	Universal Tractor Hydraulic Fluid for Wet Disc Brakes									○	SAE 10W, ISO Grade 32													Front wheel bearings	-	500 hr	Multi-Purpose Grease Extreme Pressure Lithium Soap Base																									All grease fittings - MPG	Until grease seeps from joint	-														○	NLGI EP2 FRONT WHEEL BEARINGS																										NLGI EP0 or EP1																													○	NLGI EP2																																																																																																																						
														Dexron®II ATF														Tandems - oil disc brakes - UTHF	26.5 US gal 100 L (each side)	1500 hr	-	Universal Tractor Hydraulic Fluid for Wet Disc Brakes									○	SAE 10W, ISO Grade 32													Front wheel bearings	-	500 hr	Multi-Purpose Grease Extreme Pressure Lithium Soap Base																									All grease fittings - MPG	Until grease seeps from joint			-												○	NLGI EP2 FRONT WHEEL BEARINGS																										NLGI EP0 or EP1																													○	NLGI EP2																																																																																																																																																	
Tandems - oil disc brakes - UTHF	26.5 US gal 100 L (each side)	1500 hr	-	Universal Tractor Hydraulic Fluid for Wet Disc Brakes									○	SAE 10W, ISO Grade 32													Front wheel bearings	-	500 hr	Multi-Purpose Grease Extreme Pressure Lithium Soap Base																									All grease fittings - MPG	Until grease seeps from joint	-														○	NLGI EP2 FRONT WHEEL BEARINGS																										NLGI EP0 or EP1																													○	NLGI EP2																																																																																																																																																																													
Front wheel bearings	-	500 hr	Multi-Purpose Grease Extreme Pressure Lithium Soap Base																									All grease fittings - MPG	Until grease seeps from joint			-												○	NLGI EP2 FRONT WHEEL BEARINGS																										NLGI EP0 or EP1																													○	NLGI EP2																																																																																																																																																																																																								
All grease fittings - MPG	Until grease seeps from joint	-														○	NLGI EP2 FRONT WHEEL BEARINGS																										NLGI EP0 or EP1																													○	NLGI EP2																																																																																																																																																																																																																																				
														NLGI EP0 or EP1																													○	NLGI EP2																																																																																																																																																																																																																																																																	
															○	NLGI EP2																																																																																																																																																																																																																																																																																													

○ Standard factory fill

*See Cold Weather Operation in this section, page 14-29

NLGI = National Lubricating Grease Institute
Consult your Champion Distributor for alternative lubricants
Refer to engine manual for engine lubricants

NOTE: Service intervals are based on: 250 hours or 1 month, whichever comes first
500 hours or 3 months, whichever comes first
1000 hours or 6 months, whichever comes first
2000 hours or 12 months, whichever comes first

Lubrication Specifications continued

Application/ Fluid Code	Capacity	Lubricant Change Interval (see note)	Filter Change Interval	Fluid Type	Air Temperature Range During Fill Period														
					°C -40	-30	-20	-10	0	10	20	30	40	50	°F -40	-22	-4	14	32
All Wheel Drive pump drive gearbox - GO	0.3 US gal 1,0 L	First 100 hr then 1000 hr	-	Hypoid Gear Oil - API GL-5 MIL-L-2105C	SAE 85W-140														
					SAE 80W-90														
					SAE 75W-90														
All Wheel Drive planetary reduction unit - GO	0.4 US gal 1,5 L (each side)	First 100 hr then 1000 hr	-	Hypoid Gear Oil - API GL-5 MIL-L-2105C	SAE 85W-140														
					SAE 80W-90														
					SAE 75W-90														
Final drive - single reduction lock/ unlock differential - GO	6 US gal 23 L	First 100 hr then 1000 hr	-	Hypoid Gear Oil - API GL-5 MIL-L-2105C	SAE 85W-90														
					SAE 80W-90														
					SAE 75W-90														
Final drive - double reduction lock/ unlock differential - GO	9 US gal 34 L	First 100 hr then 2000 hr	-	Hypoid Gear Oil - API GL-5 MIL-L-2105C	SAE 85W-90														
					SAE 80W-90														
					SAE 75W-90														
Drum brake/clutch fluid - MVBF	-	1 year	-	Motor Vehicle Brake Fluid	SAE J 1703, DOT 3, ISO 4925														
Oil disc brake fluid - PBF	-	1 year	-	Petroleum Base Fluid	Shell Aeroshell Fluid 4			Shell Tellus T15			Esso Univis N Arctic								

○ Standard factory fill

API = American Petroleum Institute
Consult your Champion Distributor for alternative lubricants
Refer to engine manual for engine lubricants

NOTE: Service intervals are based on: 250 hours or 1 month, whichever comes first
500 hours or 3 months, whichever comes first
1000 hours or 6 months, whichever comes first
2000 hours or 12 months, whichever comes first

Lubrication Specifications continued

Application/ Fluid Code	Capacity	Lubricant Change Interval (see note)	Filter Change Interval	Fluid Type	Air Temperature Range During Fill Period																	
					°C -40 -30 -20 -10 0 10 20 30 40 50																	
					°F -40 -22 -4 14 32 50 68 86 104 122																	
Transmission - EO	14 US gal 53 L	1000 hr	First 100 hr then 500 hr	Premium Quality Engine Oil * API CD/CE qualified to Allison C-3 and TO-2 specifications																		

○ Standard factory fill

*See Cold Weather Operation in this section, page 14-29

API = American Petroleum Institute
 Consult your Champion Distributor for alternative lubricants
 Refer to engine manual for engine lubricants

NOTE: Service intervals are based on: 250 hours or 1 month, whichever comes first
 500 hours or 3 months, whichever comes first
 1000 hours or 6 months, whichever comes first
 2000 hours or 12 months, whichever comes first

Cold Weather Operation

Lubricant Requirements for Transmission and Hydraulic Systems

When operating in temperatures below -20°C (-4°F), you can use the recommended oils provided the following conditions are met:

- a) Before start up, the oil is preheated to a temperature above the minimum value for the indicated oil and viscosity range.
- b) The operating temperature stays above the minimum value in the applicable range.

Failure to comply with these requirements may result in a malfunction or reduced life of the transmission or hydraulic components.

Cold Weather Start Up Procedure

If oil in the hydraulic circuit is cold, hydraulic functions may move slowly. Do not attempt grader operations until the hydraulic oil is warmed up. If you do not follow the proper warm up procedure, hydraulic pump damage may result.

1. Run the engine at approximately 1000 rpm for five minutes. Do not put load on the hydraulic system.
2. Cycle all hydraulic cylinders through their working range several times until the hydraulic functions operate normally.
3. The grader is now ready to operate under load.

